

Bystronic



efficiency in laser cutting

Bystar L

Large format laser cutting machines
for metal sheets, tubes and profiles

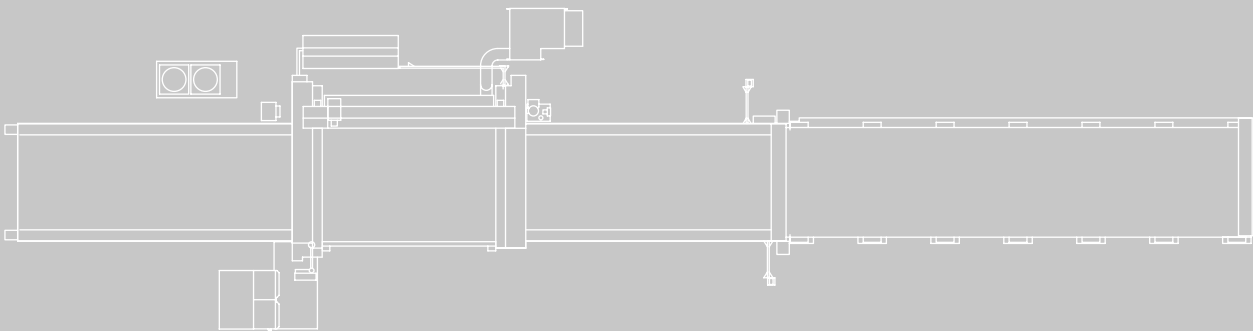

Bystar L – large, precise and autonomous

In terms of the length of the working area, the universal laser cutting machines of the Bystar L family go way beyond current boundaries, and large format metal sheets can be processed economically and without problems. And no wish remains unanswered in terms of the cutting precision with this machine. This is assured by the principle of repositioning, with which the laser beam path is kept short and accurate. In addition, a Bystar L exhibits a high level of autonomy, without the need for investment in additional automation solutions. In addition to the special features that are directly related to the size, the Bystar L provides the same versatility as the basic Bystar model, which also takes thick metal sheets, tubes and profiles in its stride. And with the Bystar L all the important components, such as the laser source and the drives, also come from a single source so that a highly reliable machine is guaranteed.



Characteristics

- Problem-free processing, even with special oversized formats
- The repositioning ensures a short beam path in spite of the large working area
- Fast processing of large-format cutting plans thanks to dynamic drive and flying optics
- High level of operating autonomy since even in the basic version, the machine design offers a high level of automation
- The division of the cutting table into working areas offers additional application possibilities
- Optimal access and a clear view of the cutting area are ensured even with the rotary axis
- Hand-held controller unit for setting up and adjusting, as well as for separation of the waste skeleton and for adjusting parameters during test cuts



Repositioning – conventional and alternated

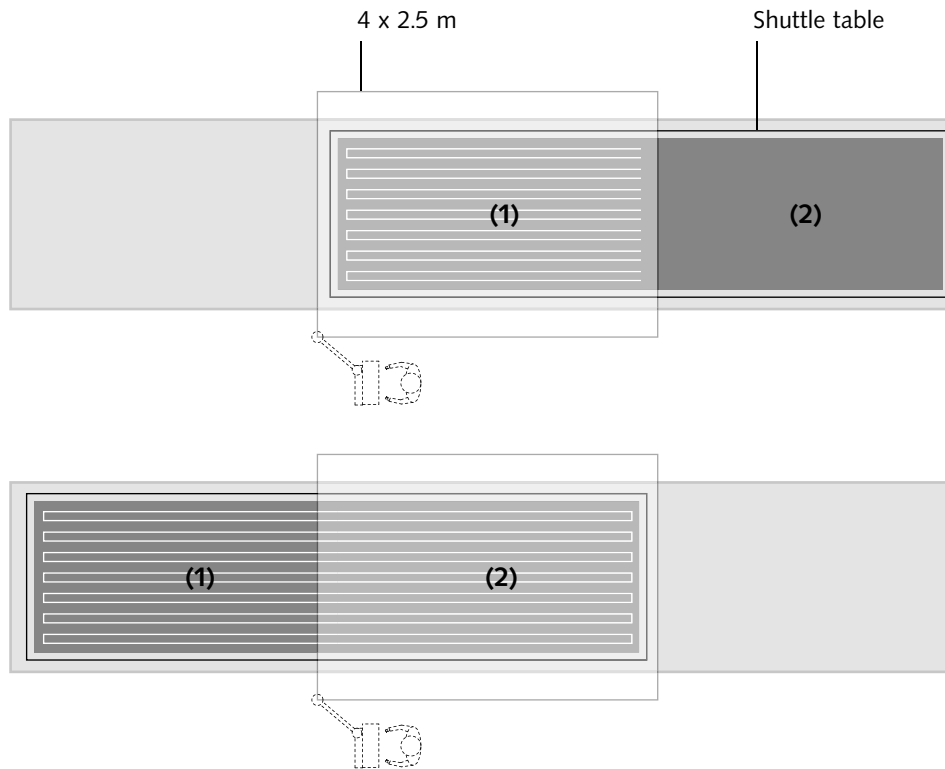

Figure 1

Conventional repositioning:

Figure 1 shows a cutting table on which a metal sheet with the dimensions 8 x 2.5 m is loaded. The complete cutting plan is divided into two cutting areas each of 4 x 2.5 meters, of which the left-hand area is processed first (1). Subsequently the cutting table is repositioned, the laser carries on with the work and processes the complete right-hand cutting area (2). This method of processing has proven itself to be particularly valuable with thin metal sheets.

Alternated repositioning:

Figure 2 again shows a cutting table, upon which a metal sheet with the dimensions 8 x 2.5 m is loaded. In this particular case, the complete cutting plan is subdivided into eight individual cutting areas. Initially cutting area 1 is completely processed, the cutting table moves forward and subsequently cutting areas 2 and 3 are processed. The cutting table then moves back and the areas 4 and 5 are cut. This procedure is repeated until all cutting areas have been processed in the order shown. Depending on the machine, the cutting plan can be subdivided into up to 30 cutting areas, which are processed in the shown pattern.

Advantage: The transfer of heat is evenly distributed across the cutting table and the stresses present in the material are only released in the individual areas. This means that the re-piercing after each repositioning is very precise. The quality of the cut parts is optimal so that even extra-long and particularly thick parts can be produced with perfect quality.

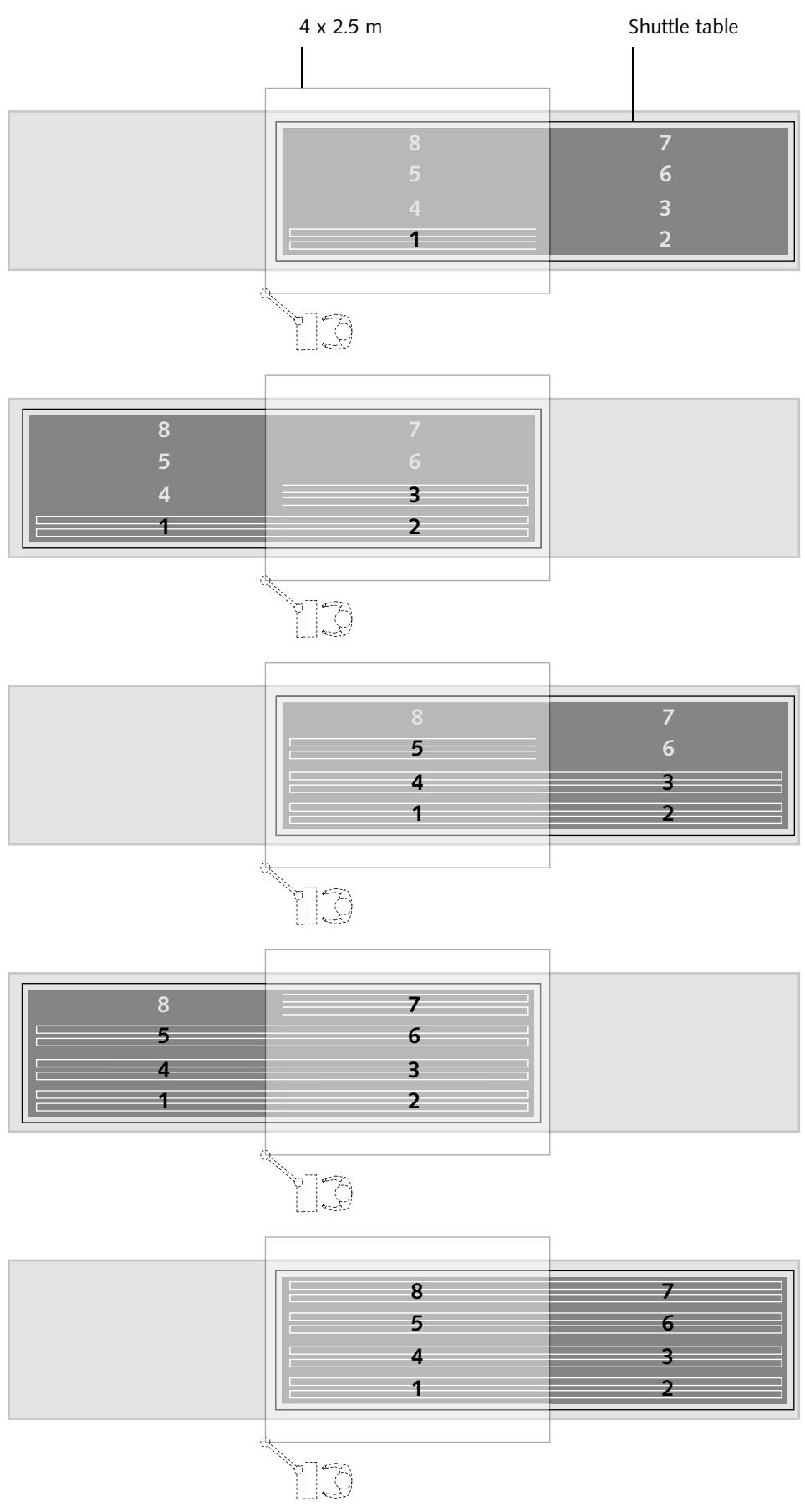

Figure 2

Areas of application

Where conventional systems with standard dimensions are no longer adequate, the Bystar L is used for the problem-free cutting of oversized, specialised formats.

The Bystar L can be used in a wide variety of market segments:

- Building machines
- Commercial vehicle construction
- Shipbuilding
- Steel service center (customer cutting jobs)
- Bridges and steel construction
- Underground railway carriage construction

Sheet metal thicknesses

Mild steel	0.5–25 mm
Stainless steel	0.5–20 mm
Aluminium	0.5–12 mm

Cross section of tubes

Fed through the chuck	15–155 mm
Direct feeding	15–315 mm

Prefabricated parts



Expansion possibilities

- Automation and handling upon request
- Rotary axis with tailstock
- Tactile sensing when cutting non-conducting materials

Customer benefits

- The Bystar L allows the user to acquire new orders and applications for large parts that are outside the range of competitors with their standard machines
- Thanks to simple and economic processing of large metal sheets, the construction of oversized parts is greatly facilitated and clearly becomes simpler and more cost efficient
- As with the basic version, the Bystar L offers the user a high degree of autonomy



Filter cover

Material: Mild steel

Steel sheet size: 6800 x 2450 mm

Material thickness: 3 mm



Filter body
Material: Mild steel
Steel sheet size: 7000 x 2500 mm
Material thickness: 6 mm

Service & Support

Bystronic's proven technology and extensive expertise produce systems that are extremely reliable. With its global network of specialised service and training experts and comprehensive spare parts inventories in the local markets, Bystronic guarantees that it will support what it sells. In addition to maintenance, spare parts delivery, and repair services, customers are also offered training programs as well as hardware, software, and operational support so that they are in a position to get the most from their machine investment.

Filter VA 2050
Material: Mild steel
Steel sheet size: 8000 x 2500 mm
Material thickness: 6 mm



This brochure may show parts that are not standard equipment, but are available as options. For the better visibility of machine details, some safety covers may have been opened or removed for these pictures. The right to make changes to dimensions, construction, and equipment is reserved. For technical data, see separate data sheet.

Bystronic is a worldwide active supplier of application-oriented systems and services for the laser and waterjet cutting processes, as well as bending: economical, high-performance, reliable.



Laser cutting
Laser cutting systems for the innovative processing of a wide variety of materials and geometries



Bending
3-point and air bending machines for high-precision working of sheet metals

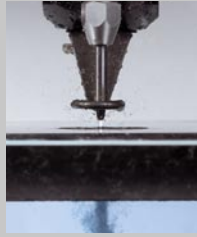

Waterjet cutting
Waterjet cutting systems for cutting metals, glass, synthetics, ceramic, and many other materials



Automation
High-performance handling and automation solutions from simple loading systems to fully automated laser production cell with integrated storage system



Software & Control
User-friendly programming and operation with requirement-oriented application programs and interfaces to CAD and ERP systems

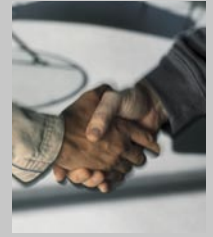

Service & Support
Competence and customer proximity with after-sales support available worldwide: local contact persons, prompt delivery of spare parts, and professional training courses

Your contact

www.bystronic.com